

Thank you for your interest in our schematics. The schematic is available on the next page.

If you want to download additional parts of a schematic, or additional schematics, these must be requested individually.

To provide you with this information, more than 6000 members work regularly on the content of Radiomuseum.org.

As a member, you can access schematics, large images without watermarks and collector's prices. You will also surf at Radiomuseum.org without advertising. To do so, you may support Radiomuseum.org with a one-time membership fee of 20 € or 30 CHF or 25 US \$. We would be delighted if you joined as a member:

https://www.radiomuseum.org/dsp_anmelden_start.cfm

These books might be of interest of you:

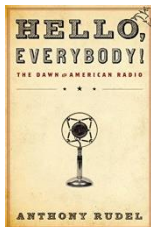

Hello, Everybody! The Dawn of American Radio

Long before the Internet, another young technology was transforming the way we connect with the world. At the dawn of the twentieth century, radio grew from an obscure hobby into a mass medium with the power to reach millions of people.

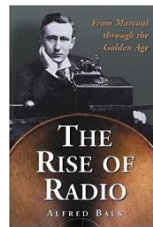

The Rise of Radio, from Marconi through the Golden Age

As the dominant form of electronic mass communication in the United States from the 1930s into the 1950s, radio helped to forge a modern continental nation. It fused myriad subcultures heavily rural, ethnic, and immigrant into a national identity, unifying the nation in the face of the Depression and war.

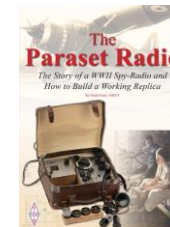

The Paraset Radio: The Story of a WWII Spy-Radio and How to Build a Working Replica

This book describes the gripping story behind the Paraset – a unique spy-radio, dropped behind enemy lines in the dark days of WWII. This radio being both light weight and state of the art for the time was concealed in a suitcase, making ideal for use by the spies of SOE.

Click [here](#) for further information.

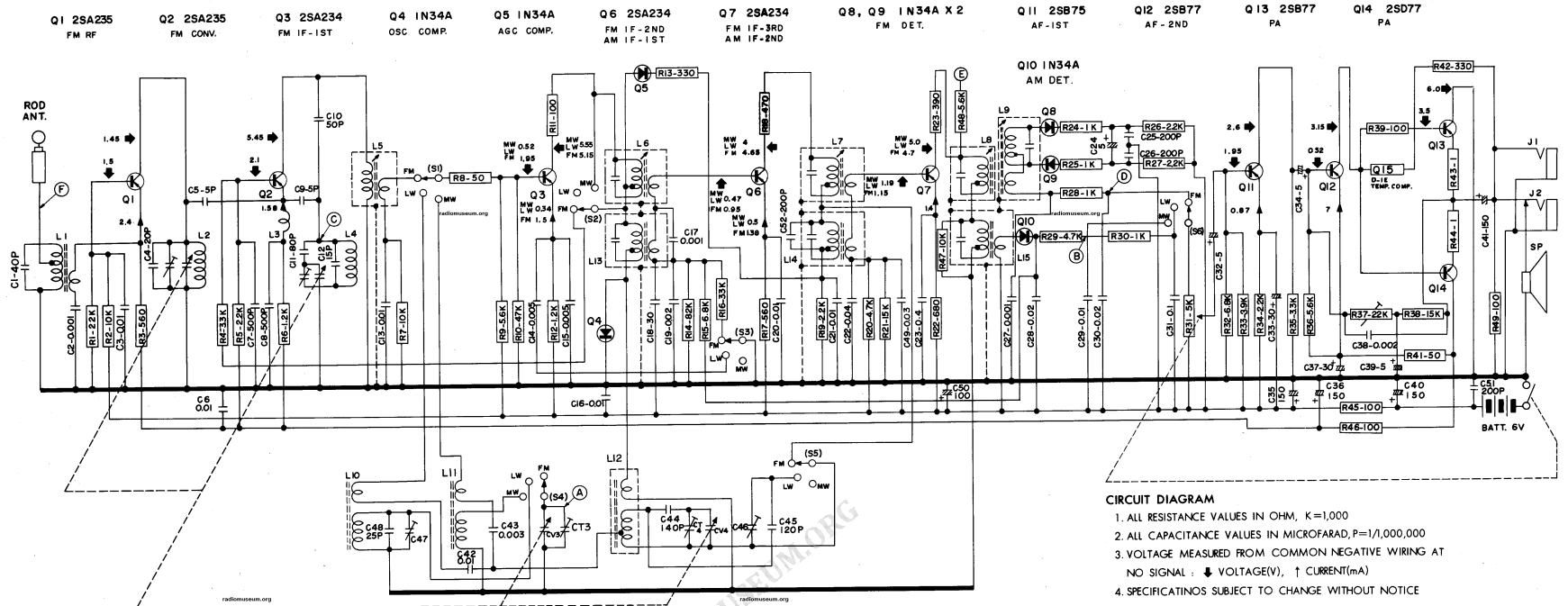

CIRCUIT DIAGRAM
 1. ALL RESISTANCE VALUES IN OHM, K=1,000
 2. ALL CAPACITANCE VALUES IN MICROFARAD, P=1/1,000,000
 3. VOLTAGE MEASURED FROM COMMON NEGATIVE WIRING AT NO SIGNAL : ↓ VOLTAGE(V), ↑ CURRENT(mA)
 4. SPECIFICATIOS SUBJECT TO CHANGE WITHOUT NOTICE

AM ALIGNMENT PROCEDURE

Steps	Connect high side of Sig. gen. to -	Sig. gen. output	Radio tuning set to.	Indicator connection	Adjust	Remarks	
1	Point (A)	45KC sweep ±35KC	-	Connect oscilloscope to the point (B)	L13 L14 L15	Function switch in MW position. Adjust top cores for max. gain and symmetry.	
2	Short wire Placed near loop for radiated signal	515KC with mod.	515KC (gang fully closed)	Connect Output meter across the voice coil	OSC Coil L12	Adjust for max. output.	
3		1650KC with mod.	1650KC (gang fully open)	"	Trimmer CT4	"	
4		600KC with mod.	600KC	"	ANT Coil L11	"	
5		1400KC with mod.	1400KC	"	Trimmer CT3	"	
6		145KC with mod.	145KC (gang fully closed)	"	Trimmer C46	Function switch in LW position. Adjust for max. output.	
7		170KC with mod.	170KC	"	ANT Coil L10	"	
8		250KC with mod.	250KC	"	Trimmer C47	"	
9		If necessary, repeat above steps for maximum sensitivity.					

Note. 1. For all alignment operation, connect the low side of the signal generator to the "common negative" wiring.
 2. Unless otherwise specified, (a) signal generator output should be modulated at 400 cycles and 30% modulation, (b) and keep the output as low as possible.
 3. Set the volume control at maximum.

FM ALIGNMENT PROCEDURE-FUNCTION SWITCH IN FM POSITION

Steps	Connect high side of Sig. gen. to -	Sig. gen. output	Radio tuning set to.	Indicator connection	Adjust	Remarks	
1	Point (C)	10.7MC sweep ±600KC	-	Connect oscilloscope to the point (D) through diode	L5 L6 L7 L8	Adjust top cores for max. gain and symmetry.	
2	"	"	"	Connect oscilloscope to the point (E)	L9	Adjust top core for 10.7MC crossover and straightness of crossover line.	
3	Point (C)	87MC with 400 cy. modulation	87MC (gang fully closed)	Connect Output meter across the voice coil	L4	Adjust for max. output.	
4		109MC with 400 cy. modulation	109MC (gang fully open)	"	Trimmer CT2	"	
5		Repeat 3 and 4.					
6		90MC with 400 cy. modulation	90MC	Connect Output meter across the voice coil	L2	Adjust for max. output.	
7		105MC with 400 cy. modulation	105MC	"	Trimmer CT1	"	
8		Repeat 6 and 7.					
9		98MC with 400 cy. modulation	98MC	Connect Output meter across the voice coil	L1	Adjust for max. output.	

Note. 1. For all alignment operation, connect the low side of the signal generator to the "common negative" wiring.
 2. Unless otherwise specified, (a) signal generator output should be modulated at 400 cycles 30% modulation, (b) and keep the output as low as possible.
 3. Set the volume control at maximum.